

(Model.)

B. J. QUATTLEBAUM.  
Portable Dental Engine.

No. 236,080.

Patented Dec. 28, 1880.

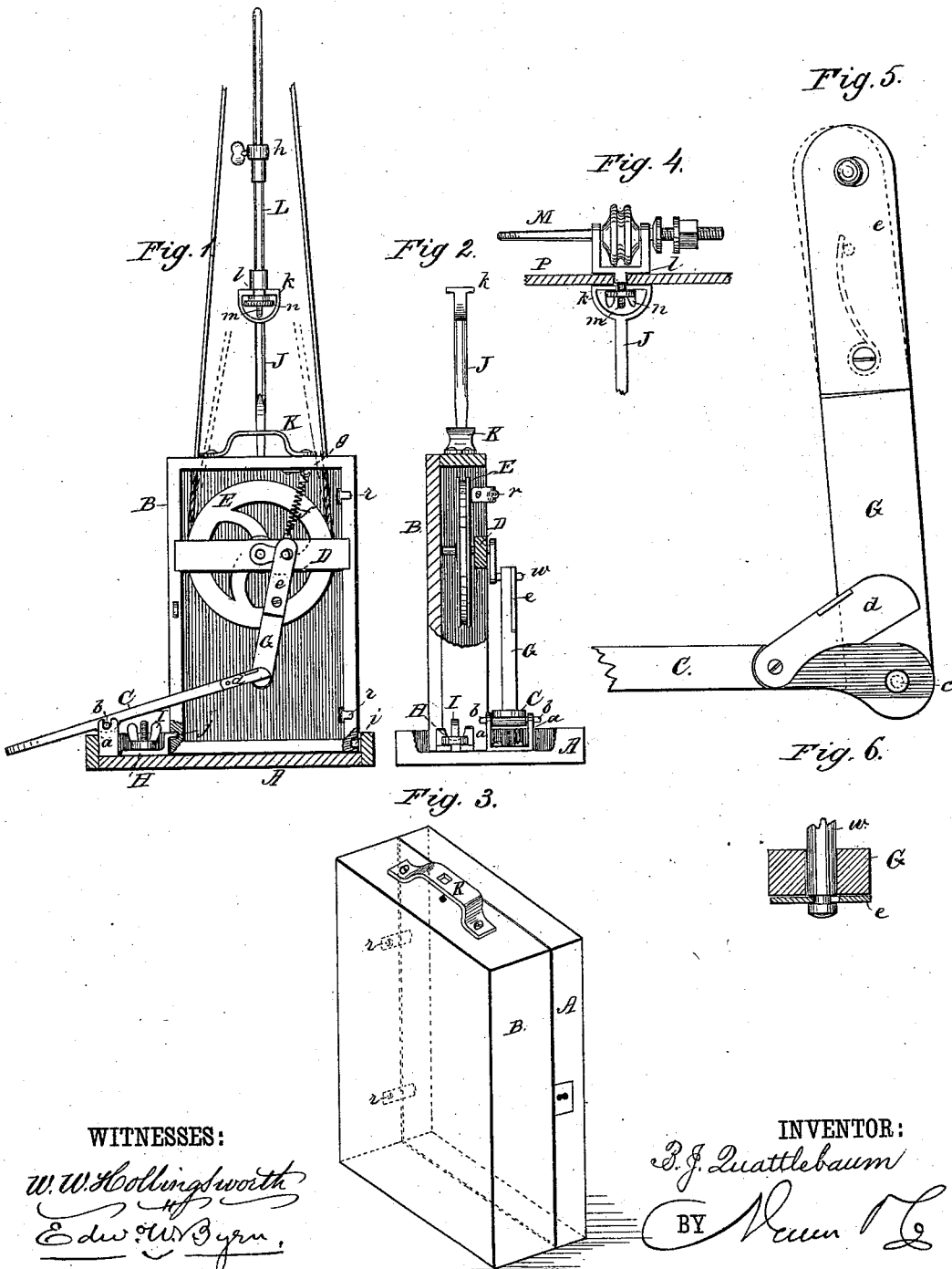

WITNESSES:

*W. W. Hollingsworth*  
*Edw. W. Byrnes*

INVENTOR:

*B. J. Quattlebaum*

BY

*Wm. C. [Signature]*

ATTORNEYS.

# UNITED STATES PATENT OFFICE.

BOLIVAR J. QUATTLEBAUM, OF WILLISTON, SOUTH CAROLINA.

## PORTABLE DENTAL ENGINE.

SPECIFICATION forming part of Letters Patent No. 236,080, dated December 28, 1880.

Application filed August 24, 1880. (Model.)

*To all whom it may concern:*

Be it known that I, BOLIVAR JONES QUATTLEBAUM, of Williston, in the county of Barnwell and State of South Carolina, have invented a new and Improved Portable Dental Engine and Lathe; and I do hereby declare that the following is a full, clear, and exact description of the same, reference being had to the accompanying drawings, forming part of this specification, in which—

Figure 1 is a side view with the basic portion in section. Fig. 2 is an edge view with parts broken away. Fig. 3 is a perspective view, showing the two sections of the frame put together to form an inclosed case. Fig. 4 is a detail, showing a modification for driving a lathe. Figs. 5 and 6 are enlarged details of the pitman-connections.

The object of my invention is to provide a combined dental engine and lathe, which may be readily set up and as readily taken down and packed within a small compass for easy transportation, the same being designed especially to fill the wants of those dentists who are compelled to leave their offices and wait upon their patients in the country or at their homes.

The invention consists in making the basic and upright portions of the frame in the nature of detachable sections of a box or case, which, when fixed in one position, form a substantial frame for the engine, and when taken down and placed together form a completely-inclosed case, adapted to carry all the parts of the engine and lathe, as well as other tools belonging to the outfit, and protect the same against loss, damage, or dirt. These are considerations of special value when the engine is required to be taken from the office.

The invention also consists in the peculiar construction and arrangement of parts for adapting the device to be used either for driving the dental burrs or for driving the dentist's lathe; and, also, further, in the peculiar construction and connection of the several parts for securing greater facility in setting up or taking down the device, and for contributing to the compact packing and ready portability of the same, as hereinafter fully described.

In the drawings, A represents the basic, and B the upright portions of the frame, which

parts are made in the nature of independent sections of a box or case, which may be set up to constitute a frame-work for the working parts when in action, as in Figs. 1 and 2, or may be placed together to form a completely-inclosed box or case containing all the working parts, as shown in Fig. 3. The basic section A of the frame I make much shallower than B, and adapt it to receive the treadle C, while the section B has a cross-bar, D, in which and in the side of the case are arranged the journals of the grooved band-pulley E, which drives the band F.

In the lower basic section, A, near one end, are fixed permanently the forked supports *a*, in which pins *b b* on the treadle C rest to form a bearing and a fulcrum. The outer end of this treadle is jointed to a pitman, G, and this pitman is connected to the crank of the drive-pulley E. To permit the ready disconnection of these parts the pins *b* simply rest in open slots in the supports *a*, so that the treadle can be lifted out, and the outer end of the treadle is jointed to the pitman by a headed pin, *c*, Fig. 5, which is held in place against any tendency to come out by a pivoted latch, *d*, which folds down over the head of the pin, so that the parts may be readily disconnected by simply throwing back the latch and taking out the pin.

For the quick and secure connection of the pitman to the crank also, I make the wrist-pin *w* of the latter with a groove near its end, (see Fig. 6,) and the upper end of the pitman is provided with a face-plate, *e*, Fig. 5, having a hole for encircling the wrist-pin. This plate is pivoted at its lower end to the pitman, and is strained by an underlying spring of rubber or metal, so that the plate has a tendency to pass out of coincidence with the hole in the pitman, as in Fig. 5. Now, when the pitman is to be connected to the wrist-pin the face-plate is sprung back so that the hole in the plate coincides with the hole in the pitman, as shown in dotted lines, to permit the wrist-pin to pass through, after which the face-plate springs into the groove in the wrist-pin, and holds the pitman from slipping off. This connection for the pitman is very simple and effective, and can be made or broken by a single movement. Now, it will be seen that as

the treadle is oscillated, the band-pulley is operated through the pitman and crank.

To give an elastic return movement to the treadle, so as to more readily pass the dead-center, a spring, *f*, is connected to the upper end of the pitman, and to a hook, *g*, on the upright portion of the case, which hook is made to swing inwardly when the sections of the case are placed together.

For connecting the section B firmly to A in its upright position a pair of spurs or lugs, *i*, Fig. 1, on the inner end of the base part A, are made to enter corresponding holes at the lower end of B, and the section B is held into engagement therewith by a slotted plate, H, on the other side, fixed in the bottom of the base part, which plate has spurs *j*, fitting into similar holes in the lower edge of section B. The section B is first fitted up to the lugs or spurs *i*, and the plate H is then moved up into engagement with B, and after its points or lugs enter the holes in the same it is clamped in place by a set-screw, I, which secures the plate to the bottom of the basic section. To prevent wearing away the edges of the sockets for the lugs, said sockets are preferably bound with metal.

On top of the section B is arranged the detachable standard J, which sustains the flexible shaft driving-pulley, or lathe-pulley, as the case may be. This standard has a squared end, which fits snugly down through a brace, K, and enters a socket in the top of the said frame-section B. This brace K serves a double function: in the first place it braces or stays the upright standard J stiffly in place; and, secondly, when the two sections of the case are folded together it forms a convenient and substantial handle for transporting the device. To adapt the standard J to carry either a lathe or a pulley for driving the burrs its upper end is formed with a horizontal plate, *k*, slotted to its center from the outer edge, which plate has an eccentric connection with the body of the standard by bifurcated arms or branches, forming an inverted-stirrup-shaped device. Now, to this plate may be fixed either the post L, for carrying the pulley which drives the burrs, or the lathe M. (Shown in Fig. 4.) Both the post L and the lathe-frame have a shoulder, *l*, a pendent screw-threaded stem, *m*, and a nut, *n*, which parts are connected to the plate *k* by slipping the screw-stem laterally in the slot in plate *k*, and then clamping the plate *k* between the shoulder *l* and the screw-nut. The post L has in its length a telescopic joint and set-screw *p*, which permits the upper section, carrying the burr-driving pulley, to be elevated to tighten the belt, and the lathe M has the usual lathe-wheel, with chucks and screw-mandrel, for holding the emery-disk and connecting with the rotary tools. The lathe-stem *m* is also made of such length that a piece of board, P, may be clamped between its frame and the plate *k* to constitute a table. For the lathe a shorter belt is required, as shown in dotted lines.

All the parts of this device, it will be seen, can be readily separated and packed within the sections of the case, which are held together by hooks *r r* in section B, which fit into recesses *s s* in the other section, A, on one side, while the other two sides are fastened by a lock and key.

I am aware of the patent to Wilkerson, No. 215,851, in which a dental-engine case is made in the nature of a series of trays, one of which carries the drive-wheel, and I do not, therefore, claim as my invention a sectional dental-engine case. My invention, it will be seen, differs from the above in that one section of the case constitutes the basic support, and the other the carrying-frame, and the engine can be used without scarfing tables or other pieces of furniture, and without requiring a different adjustment of the treadle. Both of the two sections of my case are always utilized together—at one time for a supporting-frame in right-angular planes, and at another as a containing-case in parallel planes.

Having thus described my invention, what I claim as new is—

1. A frame for a dental engine or lathe, composed of two detachable parts—an upright section and a basic or horizontal section—provided with means for connecting the same together in planes at right angles, and adapted, when taken down and placed together, to form an inclosing-case for the working parts, substantially as shown and described.

2. The combination of the section A, carrying bearings for the treadle, the section B, carrying the band-pulley and crank, the detachable pitman G, and the treadle C, substantially as described.

3. The combination of the detachable case-sections A and B, having lugs or spurs and corresponding sockets, and a sliding clamp-plate, H, for connecting the two rigidly together, as set forth.

4. The combination, with the section B and the detachable standard J, of a perforated brace for sustaining the standard, made in the shape of a handle, as described.

5. The standard J, connected eccentrically to a slotted plate, *k*, in combination with a supporting-frame having a shoulder or stem, *m*, and a nut, *n*.

6. The lathe M, having elongated stem *m* and nut *n*, in combination with an interposed detachable table, P, and the standard having slotted plate *k*, substantially as shown and described.

7. The combination, with the grooved wrist-pin, of the pitman having a face-plate perforated to receive the wrist-pin and strained by a spring so as to enter the groove and prevent the pitman from slipping off, as set forth.

The above specification of my invention, signed by me this 17th day of August, 1880.

B. J. QUATTLEBAUM.

Witnesses:

EDWD. W. BYRN,  
 SOLON C. KEMON.